



SCREW AIR COMPRESSOR USER MANUAL

DIRECTORY

CHAPTER ONE: SAFTY ATTENTION.....	4
CHAPTER TWO: INSTALLATION STANDARDS AND REQUIREMENTS	5
A、 HANDLING ATTENTION.....	5
B、 INSTALLATION ENVIRONMENT LAYOUT REQUIREMENTS.....	6
C、 INSTALLATION PROPOSALS.....	7
D、 INSTALLATION REQUIREMENTS.....	8
E、 THE CONFIRMATION OF AIR SUPPLY SCHEME.....	9
F、 THE CONFIRMATION OF AIR CAPACITY.....	10
CHAPTER THREE: MACHINE SYSTEM STRUCTURE, PROCESS AND FUNCTION..	11
A、 AIR END STRUCTURE AND WORKING PRINCIPLE.....	11
B、 SYSTEM FLOW CHART.....	13
CHAPTER FOUR: ELECTRICAL CONTROL SYSTEM AND CIRCUIT.....	14
A、 LOW VOLTAGE POWER SUPPLY AND PERIPHERAL CONNECTION REQUEST.	14
B、 CONTROL SYSTEM FUNCTION.....	15
C、 ATTACHMENT.....	17
CHAPTER FIVE:PIPE LINE CONFIGURATION AND INSTALLATION.....	20
CHAPTER SIX: OPERATIONAL GUIDELINES.....	23
CHAPTER SEVEN:DAILY MAINTENANCE.....	25
A、 LUBRICATING OIL SPECIFICATION AND USE.....	26
B、 CONTROL DEVICE ADJUSTING.....	27
C、 THE MAINTENANCE OF MACHINE CONSUMABLE PARTS.....	28
D、 THE MAINTENANCE OF SCREW AIR COMPRESSOR.....	29
CHAPTER EIGHT:COMMON FAULTS AND PROCESSING.....	30
CHAPTER NINE: MANTENANCE RECORD.....	35

THANK YOU FOR CHOOSING BALDOR SCREW AIR COMPRESSOR

GUANGDONG BALDOR-TECH CO., LTD has the right to change the design. But it is not responsible for the corresponding modification and improvement of products out of the factory. Later we may change the specifications and parts of the products without prior notice.

The machine has past strict inspection and testing before they leave the factory. In order to ensure the machine works safely, in long-term use and good working condition, please read the user manual before machine works. Do not change the parameter which has been adjusted in the factory.

Chapter One: Safety Attention



Read it carefully before operating the air compressor safely

1. Before install the piping welding, move the near flammable items and prevent welding spark dropping into the air compressor.
2. The power of the air compressor supplying line must be matched with air switch, fuse and the other safety device. The line must have grounding device. Install lightning protection device if it is necessary.
3. The machine must be tested by our company or approved personnel.
4. Pay attention to the rotating direction of the machine when start the machine for the first time or change the power line.
5. The air compressor can't work upon the exhaust pressure that is higher than the nameplate prescribed.
6. Do not sure to start machine forcibly when the air compressor is in malfunction condition or there's unsafe factors. Should cut off the power supply, and make a significant mark.
7. Compress air and electrical appliances are dangerous. Make sure the power supply has been cut off when repair or maintain it. And hang "repair" or "no switching" marks in the power place.
8. Must wait the air compressor cools down and the air is released safely, repair or maintain it when the internal pressure of machine is equal to atmospheric pressure.
9. Use no corrosive safe fusing agent to clean the machine parts. It is strictly prohibited to use flammable and volatile cleaner.
10. Regularly check the safety valve and the other protection system after operating the air compressor for a period time, and ensure it is sensitive and reliable. Check it once per year generally.
11. The parts of air compressor must be provided by original factory, and the oil must be our company designating screw air compressor oil. Does not mix use two different brands of oil; otherwise it will cause system coke to a serious accident.

12. Air compressor should be operated by permanent staff. Operator should read through and understand the contents of this manual, following the instructions of the working procedures, safety precautions and maintenance instructions.

13. The compressor can not be directly used as produce breathing equipment, if you want to achieve breathing standard, compressor should do corresponding purification treatment.

14. The machine door should be closed when it working. Only open for inspecting in a short time. Avoid the harm to human body by the working parts and high temperature parts of it.

15. Pressure vessel can not be welding repair and not use fire for inspection machine or the internal parts.

All violate of safe matter behavior may cause serious accidents.

Chapter Two: Installation Standards And Requirements

a、HANDLING ATTENTION

1. In order to carry safely, pay attention to the total weight of the machine.

2.To ensure balance when the crane carry, pay attention to the placing of steel wire rope. Prepare slings to prevent the steel wire rope extruding, which will damage the body.

3. Use the soft liner protection to prevent compressor surface damaging when forklift carry. Forklift fork should insert the air compressor base completely.

b、 INSTALLATION ENVIRONMENT LAYOUT REQUIREMENTS

- 1. Machine room should be close to the load centre, so as to shorten the length of pipe, reduce the pressure loss & power consumption, and guarantee the air supply pressure.**
- 2. Consider the rationality of the power supply, water supply when planning the room position.**
- 3. There should be enough lands for expanding around the room in order to adapt to the needs of the development.**
- 4. Air compressor directly sucks air. In order to lower the possibility of the machine's wearing, corrosion and explosion, there must be a certain distance between the air compressor room and the place which sends out explosive, corrosive, poisonous gas, dust and other harmful substances. What's more, the room should be located in the place of the minimum frequency wind to make sure it is affected the least by harmful substances. The distance between compressor and harmful substance emission source is suggested. Please see the table2-1 below.**

Distance between compressor and harmful substance emission source

the name of harmful substance emission source	the relation with the wind orientation	level distance(m)
the place which will send out flammable gas(acetylene, gas)	any wind orientation	≥20
the chimney and discharge pipe which send out dust	The underside of local minimum frequency wind	≥50
the place which sends out dust	unfavorable wind	≥50
	favorable wind	≥20

1. Due to the large heat release of the compressor, especially in summer, the inner temperature is high, so the machine room should be well ventilated and less sunlight.
2. Though there is a case outside the air compressor, it is strictly prohibited from rain and sunlight. Therefore, the compressor should not be installed outdoor.
3. The compressor room should be set up as an independent building. The minimum distance with other buildings, structures is as the table 2-2 below:

Workshop fire prevention distance

fire prevention distance(m) fire resistant rating	1st & 2nd grade	3rd grade	4th grade
1st & 2nd grade	10	12	14
3rd grade	12	14	16
4th grade	14	16	18

c、INSTALLATION PROPOSALS

- 1、 the smallest installation space of air compressor(mm)

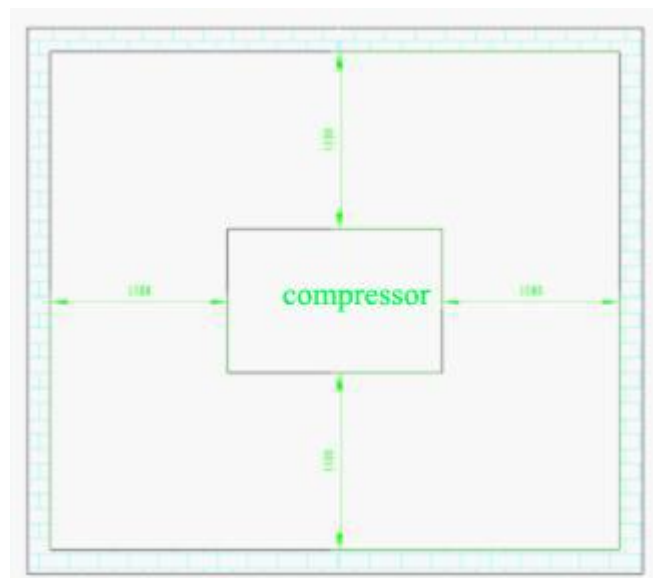

d、INSTALLATION REQUIREMENTS

1. Leave enough room for repairing and maintaining the air compressors.
2. The ground is best to be smooth cement floor. The air compressor base should be placed at the concrete platform above the ground 150 mm high, and platform levelness is not more than 0.5/1000 (mm). And there should be grooves around and on the platform, and then the oil and water can flow away through the groove when stopping the machine for changing oil, repairing or washing the ground. The size of the groove is decided by the user.
3. Make sure the bottom of the compressor is placed evenly on the platform, which can minimize vibration and noise.
4. For users in good economic condition, acoustic board can be fixed on the inner wall to further reduce the noise, but should not use ceramic tile or the other hard surface materials.
5. Air cooled type compressor is much influenced by environmental temperature, so the room should be ventilated, dry, inner with exhaust fan. The environment temperature of compressor should be controlled within $-5\text{ }^{\circ}\text{C} \sim 40\text{ }^{\circ}\text{C}$.
6. The air of workshop should be clean, no dust, harmful gases, sulfurous acid and the other corrosive medium.
7. Air compressor is heating equipment, especially the cooled type compressor, so the ventilation of workshop is very important. It is necessary to install the air draft equipment in accordance with the outside wind orientation. The pumping volume must be higher than that of air compressor cycle fan or cooling fan, and cooling air inlet area should be large enough. Also can install a guiding wind hood at the top of the air compressor's air exhaust fan, which can siphoned off the hot air discharged by the air compressor through the pipe to maintain the room temperature within $5 \sim 40\text{ }^{\circ}\text{C}$.

When using exhaust pipe, leave enough space to install canvas active connector for maintenance (for example, when cleaning cooling unit, there's enough space dismantling compressor cover and the other parts).

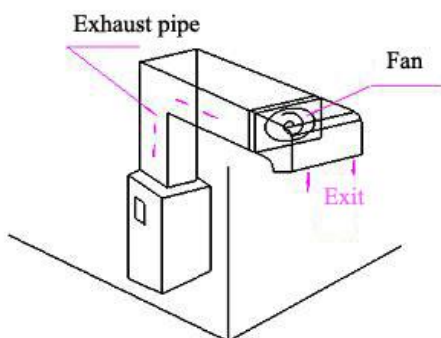

e、 THE CONFIRMATION OF AIR SUPPLY SCHEME

According to the workshop size, air distribution, the air supply pressure level, air quality grade and other factors, we confirm several air supply plans by comprehensive consideration and technical & economic comparison.

1. The chief air compressor station supplies air.

That is built a chief air compressor station to provide all the air users. This scheme is suitable for small, medium-sized factories and users quite centralized in large factories.

2. Regional air compressor station supplies air.

When factory is big, air consumption is large and the main users are dispersive, to avoid the pipe is too long causing pressure drop and ensure the air supply to main users, often use this air supply plan. There should be pipes connecting each other among the regional stations to adjust the load and share mutually. At the meantime, should consider the reserved volume and units of the station together.

3. supply air on the local

When the air consumption in the factory is small and users are less and dispersive, there is use small compressor to supply air on the local. The machine can be placed on one end of the workshop or slope room and also can be placed near the using point.

4. supply air with a plan of combining centralization and dispersion

In some large and medium-sized factories, the main air compressor users concentrate, secondary users are much dispersive, or each team user imbalance, especially uses imbalance. Under this condition should use this plan.

f、 THE CONFIRMATION OF AIR CAPACITY

1. Calculate the air capacity according to the sum of average consumption

$$Q_2 = \sum Q_0 K (1 + \Phi_1 + \Phi_2 + \Phi_3) m^3 / h$$

Q_2 : air capacity m^3 / h

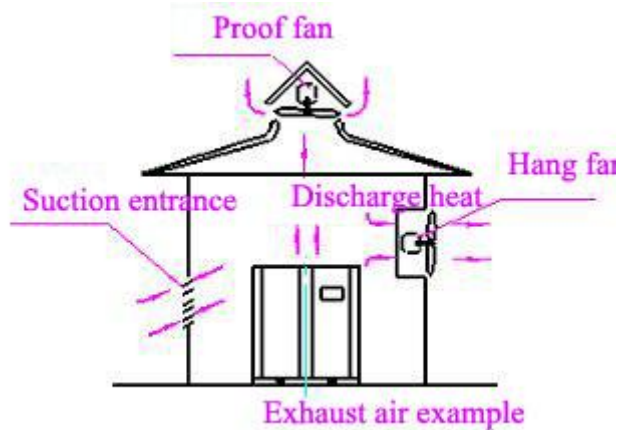

$\sum Q_0$: m^3 / h :sum of air compressor or workshop average consumption

K : Consumption inequality (maximum) coefficient 1.2-1.4

Φ_1 : The leakage coefficient of connect pipeline. When the pipe length is less than 1 km, take 0.1; Shorter than 0.5 km, take 0.15; Longer than 2 km, take 0.2.

Φ_2 : using air equipments wearing consumption coefficient is 0.15 ~ 0.2

Φ_3 : Unforeseen consumption coefficient is 0.1.

2. Calculate the air capacity according to maximum consumption

$$Q_2 = \sum Q_{\max} K'_2 (1 + \Phi_1 + \Phi_2 + \Phi_3) m^3 / h$$

$\sum Q_{\max}$: m^3 / h sum of using air equipment or workshop average consumption

K'_2 : The coefficient during the same period (according to various industries, by empirical data, it can also be determined with reference to the K'_2 value of the similar projects).

Φ_1, Φ_2, Φ_3 the same with the above

3. Calculate the air capacity according to comprehensive situation

$$Q_2 = (Q_1 + \sum Q_0)(1 + \Phi_1 + \Phi_2 + \Phi_3)m^3 / h$$

Q_1 : the maximum consumption of the main using air equipment

$\sum Q_0$: the average consumption of other using air equipment

This method can be used for the individual high air consumption equipment. Calculate the capacity of the air compressor station which Q_1 and Q_0 are very different.

Among the three calculation methods, each industry should choose it according to the characteristics of the industry, the traditional habit and experience.

When the purification system with a heat or no heat regenerative adsorption dryer, the air capacity should be each increased 8% ~ 10% or 15% ~ 20% regeneration air consumption.

In plateau area, the air capacity should also take consider of the height of the region multiplied by the following table 2-3 plateau correction coefficient.

Plateau correction coefficient

altitude(m)	0	305	610	914	1219	1524	1829	2134	2438
correction coefficient	1.0	1.03	1.07	1.10	1.14	1.17	1.20	1.23	1.26

Chapter Three: Machine System Structure, Process And Function

a、air end structure and working principle

1、the schematic diagram of screw air compressor air end

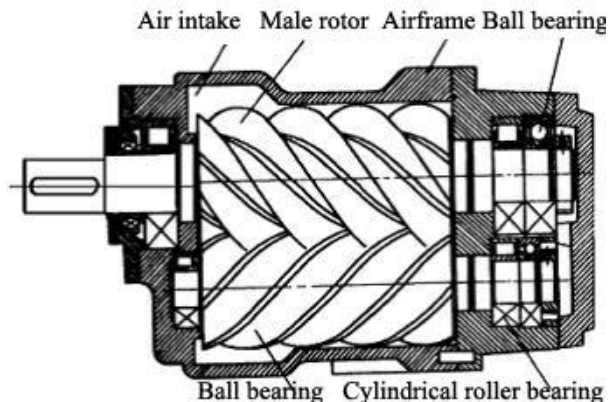

2、 working principle

Working cycle can be divided into three processes: suction, compression and exhaust.

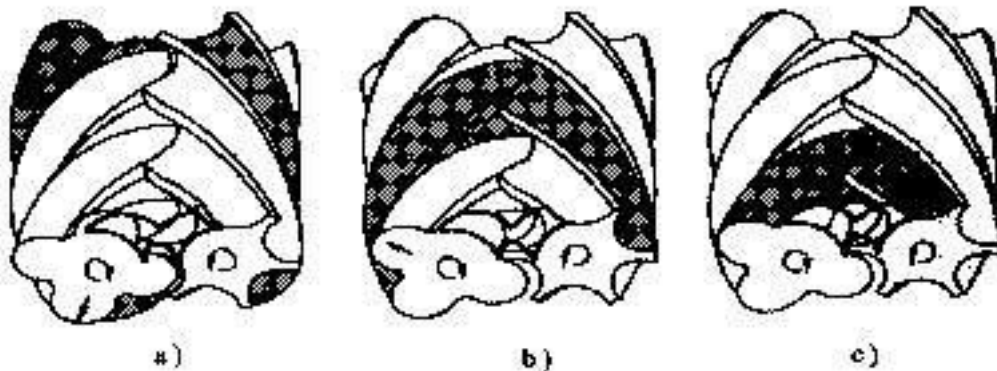

Picture1-3 Compression process of screw air compressor

a) Compression star

b) Compressing

c) Compression stop and star exhaust

2.1 suction process

As shown in picture a (screw compressor suction process), the pair of gear is arrowed. Male rotor rotate clockwise and female rotor anti-clockwise. As in the picture a, the rotor end is for exhaustion. When the rotor rotates, the gear meshing with each other in the inlet end gradually disconnect, thus the composition of the gear space volume increase gradually, and it connects with the air inlet, beginning to breathe in. Rotor continues to rotate, and gear space volume increase. When gear space volume achieves the maximum, that is, the gear with suction orifice is off, the suction process is over.

2.2 compression process

As shown in picture b, it is the compression process of screw compressor. Male and female rotor gear mesh with each other to form a complete sealing connecting line and the air is surrounded in a closed volume by rotor gear and casing. When the rotor rotates, the gear connecting line moves towards the exhaustion end and the closed volume among tooth gradually decreases, and its air pressure increases. When the gear space volume connects with the exhaust orifice, air is compressed over.

2.3 exhaust process

As shown in picture c, gear space volume is divided by the rotor connecting line into low pressure side and high side. When the volume of high pressure side connects with the exhaust orifice, which is the exhaust process, the volume of low pressure side is in suction process. Along with the rotor rotating, the volume of high pressure side reduces to zero, and the air is all discharged. At the same time, volume of the low pressure side achieves maximum, completing the suction process. So that the suction, compression, exhaustion processes go cycling.

b、 system flow chart

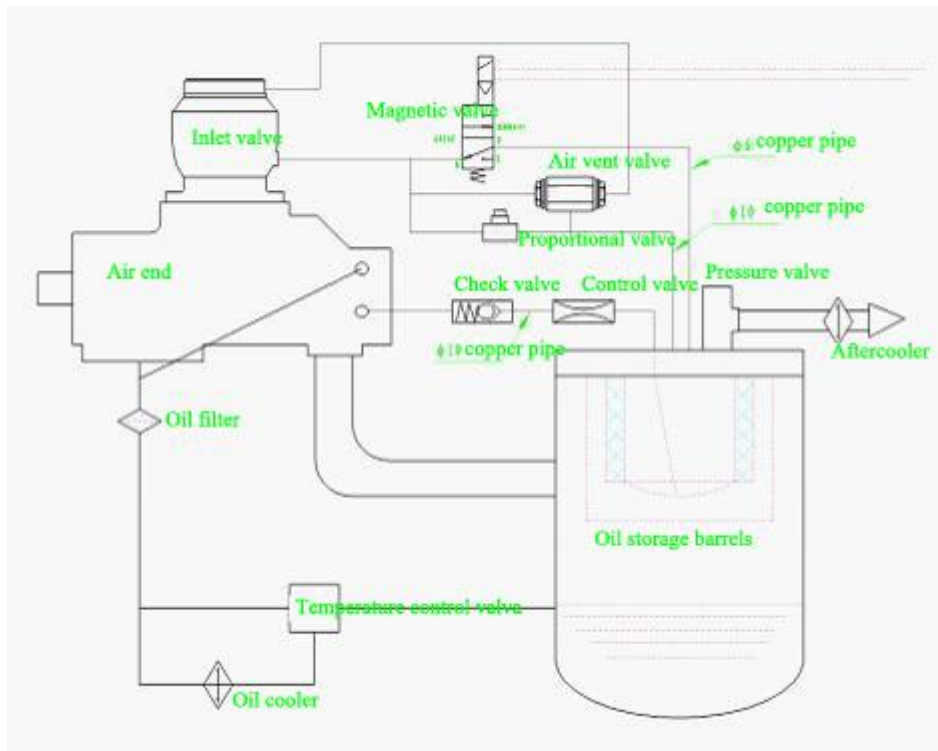

Air compressor process includes air system, lubricating oil system and cooling system.

1 air system process

After air into the air filter removing dust, it is compressed in the air end through the inlet valve. The compressed oil mixing with air go into the oil-air separator, then the filtered air go through the minimum pressure valve, cooler, air water separator, and finally discharge by the air-supply valve (air water separator can be installed after the air supply valve, according to the needs of users). The separated oil stays in oil-air separator tank, then go into the oil circulation system.

2 lubricating oil system process

Lubricating oil system is composed of oil and gas separator, temperature control valve, oil cooler, oil filter, etc. The oil in oil-air separator is driven into oil pipe under the air pressure, then goes through the temperature control valve, oil cooler and the oil filter, finally is divided into two flows, one flow injecting to air end, another flow into the front and back bearing to lubricate the bearing. The two flows are combined in the air end, mixing with the air, going into the oil-air separator, separated by the oil-air separator, staying in oil-air separator, and into the next cycle.

3 cooling system process

Screw air compressor is divided into air cooling type and water cooling type, through the fan or water forcing cooling.

Air cooling system consists of cooling fan, oil coolers and air cooler. The cooled air is pumped into the fan; go through oil cooler and air cooler, and at the same time, cool and compressing lubricating oil and air. Please pay attention to the cleaning and maintaining of the cooler surface.

Water cooling system mainly consists of the water cooler, including oil-water cooler and air-water cooler, cooling air and oil at the same time. The water supply system is installed by the customer. Please pay attention to the cooling water managing.

Chapter Four: Electrical Control System And Circuit

a、Low voltage power supply and peripheral connection request

1、Low voltage power is alternating current three phase 380V, 50Hz.

2、Voltage drop will be no more or no less than 5% of the rated voltage, and the phase voltage variance is within 3%. And there should be phase sequence protecting line.

3、Compressor power supply must be equipped with isolating switch, in order to prevent the short circuit resulting of default phase operation.

4、Check the secondary circuit fuse, and choose proper no wire safety switch according to the compressor power watt level.

5、Our air compressor user power line size is in the list below.

Line size

Compressor model. HP/KW	voltage (V)	frequency (Hz)	maximum current (A)	line size (mm ²)
7.5/5.5	380	50	15	6
10/7.5	380	50	20	6
15/11	380	50	29	10
20/15	380	50	35	10

30/22	380	50	50	16
40/30	380	50	67	25
50/37	380	50	86	35
70/55	380	50	128	60
100/75	380	50	165	80
125/90	380	50	179	125
150/110	380	50	217	150
175/132	380	50	242	185
220/160	380	50	292	240
270/200	380	50	348	300
340/250	380	50	433	400
430/315	380	50	544	400

6、 The compressor should use a set of electric power systems alone, avoiding using connect with the other different power consumption system, especially when the compressor power is high, which may cause the compressor overload due to high voltage drop or three phase current unbalance, making the protection device jump.

7、 Connect ground line to prevent leakage danger. Do not connect to the air delivery pipe or cooling water pipe!!!!!! (If the local regulation is stricter than the above requirements, follow the provisions of the local.

b、 Control system function

A series of BALDOR air compressor

1、 start machine

When switch on, first, observe whether the power is in phase inversion. The machine has phase sequence protection. If it is in phase inversion, the motor can't move. It can start again only adjusting phase sequence. Press the "start" button on the panel, then the compressor will start with "Y" way and working with "△" way.



It is strictly prohibited that the machine starts with load (exhaustion pressure shows pressure). Otherwise it will damage the electrical components because of the large starting current.

2. Adjust load in the operation process

Control system has the automatic adjustment function. When the using air decreases, the air pressure increases. If the pressure achieves the rated maximum, the control system will send signals to the electromagnetic valve, controlling air inlet valve, make inlet valve close

main engine air inlet. Thus, only little air can go into the main engine to ensure the system lubricating oil pressure. At the same time, the relief valve in the electromagnetic valve or inlet valve automatically opens, lowering the air pressure in oil-air separator, making the system run with no-load. When the air pressure lows down to the rated limit, the control valve of the system resets, and the machine operates in full load.

When the machine work in no-load, if the pressure does not drop to the rated limit in ten minutes, system will automatically stop, and then the machine will be in standby mode.

3、 stop machine

If need stop, please press “ON (I)” on the control panel. The machine will stop after unloading for a period of time. There’s no “OFF” on the control panel, but urgent stop button. If need stop, please press the urgent button when the machine is in unloading cases.

Only when the machine is abnormal condition, can press the urgent stop button, or else it will be cause oil spitting phenomenon from the air inlet of air end!!!!!!

When the compressor is in abnormal situation (such as over temperature, over pressure, etc.), the machine will automatically stop.

4、 abnormal protection function

4.1 phase sequence protection

When the power line is in fault phase, it can't start. At this time, exchange any two inlet wire, and restart.

4.2 exhaust temperature too high protection

The machine will automatically stop and alarm when the exhaust temperature reaches to the rated temperature (generally 105 °C). Panel will appear over temperature stop. There are many reasons causing high exhaust temperature. The most common reason is that the oil cooler surface is covered by dust and dirt, making oil cooling failure.

4.3 Over pressure of exhausting air protection

When exhaust pressure exceed the rated maximum pressure because of some reasons, the machine will automatically stop and alarm and the panel will appear overpressure stop. Should check the reason, and deal it properly.

4.4 overload protection

When the machine is overload because of some reasons, the machine will automatically stop and alarm and the panel will appear overload stop. Should check the reason, and deal it properly.

4.5 Maintenance and alarm function (choose function)

There are alarm function and over pressure function. So if the machine is in these situations: air filter plugging, oil filter plugging, oil-air separator core plugging, should do corresponding processing.

C、 Attachment: (circuit)

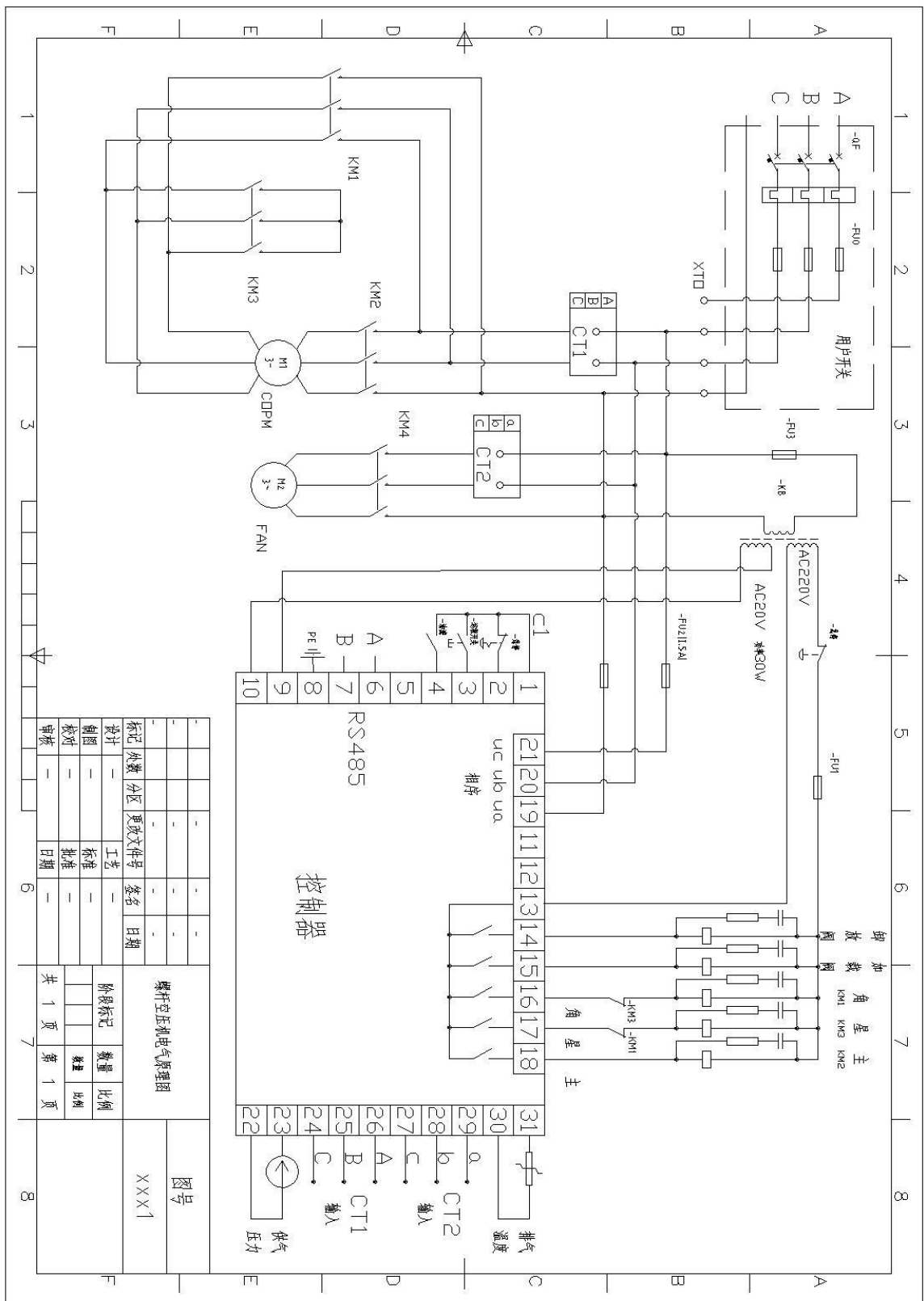

Chapter Five: Pipeline Configuration And Installation

a. pipeline installing requirements

The machine air-supply port with screw thread adapter can connect with air-supply pipeline. Please refer to the product appearance size when install.

1. When checking and maintenance, in order not to affect the overall or other machines work and prevent air from flowing back, the stop valve should be installed between the machine and the storage tank, and safety valve should be installed in the air storage tank.
2. Branch pipeline must connect from the top of the main line to avoid the condensed water flow back to the compressor.
3. Shorten the pipeline and be straight linear delivery around the whole factory to reduce the bend and all kinds of valve in order to reduce the pressure loss.

b. the general principles of the pipeline system

The pipeline system of compressing air should meet the users' needs: compressed air flow rate, pressure and air quality. And also determined from the other aspects: reliable air supply, saving energy, reducing the investment, easy maintenance, etc. Specifically as below:

1. Consider from the pressure requirements
 - a、 Pipeline system designed accord to meeting the customers' needs of highest pressure. The other need low pressure can install depressurized device on the local. Generally, common pressure of factory is 0.6 M Pa and 0.3 M Pa. The pipeline can fill 0.6 M Pa rated pressure, but install depressurized valve behind the 0.3 M Pa pressure branch line valve to meet the requirements of low pressure customers' needs.
 - b、 Pipeline system can be divided into several pressure classes according to user's pressure size, combined with the workshop or equipment arrangement, etc. Supply air by the several pressure class of pipeline system.
2. consider the air quality
 - a、 Use an untreated compressing air pipeline system. A few users who have special requirements of air quality can install small device of oil removing, drying, and purifying in local.
 - b、 Design two pipeline systems in the factory or some districts. One is for conveying untreated compressed air, other for conveying dried or oil-free compressed air.

3. consider from the characteristics of the load

Some air equipment use air very different in instantaneous maximum air volume(such as the forging hammers which use compressor power, mechanical workshop which use air power sending sand, pump and large model, etc.). In order not to affect other air equipment, generally

supply air by special line or install storage tank near the air compressor to relieve the load, making the pressure stable.

c. the selection of pipeline size

There is friction resistance in the pipe line and resistance is produced in the valve, joint, bend and the changed diameter pipe when the air flows in the pipe, leading to the loss of air pressure. The pressure drop of a section pipe line can be calculated in the table below.

Table 7-1 air flow-pressure drop of pipe line Kg / cm^2 -(100 m)

air flow m^3 / min	(inch) pipe diameter							
	1/2	3/4	1	1 1/2	1 3/4	2	2 1/2	3
0.8	5.87	1.23	0.339	0.858	0.038			
1.0	9.18	1.92	0.53	0.134	0.059	0.0157		
1.6	23.5	4.9	1.36	0.343	0.152	0.0428		
1.8	62.0	6.20	1.72	0.434	0.192	0.0541		
2.0		7.66	2.12	0.536	0.237	0.0668	0.0177	
2.2		9.26	2.56	0.649	0.287	0.0808	0.0214	
2.4		11.0	3.15	0.772	0.342	0.0967	0.0255	
2.6		12.9	3.58	0.906	0.401	0.113	0.0299	
3.0		17.2	4.77	1.21	0.533	0.150	0.0398	0.0168
air flow m^3 / min	(inch) pipe diameter							
	3/4	1	1 1/2	1 3/4	2	2 1/2	3	3 1/2
3.4	22	6.13	1.55	0.684	0.193	0.0511	0.0203	
3.8		7.66	1.94	0.855	0.241	0.0636	0.0264	

4.2		9.35	2.36	1.05	0.295	0.0780	0.0311	
4.4		10.3	2.54	1.15	0.323	0.0855	0.0341	0.0158
4.8		12.2	3.09	1.36	0.385	0.102	0.0406	0.0189
5.0		13.3	3.35	1.48	0.418	0.111	0.044	0.0204
5.5		16.0	4.06	1.79	0.505	0.134	0.0533	0.0244
6.0		19.1	4.82	2.13	0.601	0.159	0.0634	0.0299
air flow m^3 / min	(inch) pipe diameter							
	1 1/2	2	2 1/2	3	3 1/2	4	5	
6.5	2.50	0.709	0.187	0.0744	0.0346			
7.0	2.90	0.815	0.217	0.0863	0.0401			
7.5	3.33	0.940	0.249	0.0990	0.0460			
8.0	3.79	1.0	0.283	0.113	0.0524	0.0247		
8.5	4.28	1.21	0.319	0.127	0.0590	0.0309		
9.0	4.80	1.35	0.358	0.143	0.0662	0.0347		
9.5	5.35	1.51	0.399	0.159	0.0738	0.0386		
10	5.93	1.67	0.442	0.176	0.0818	0.0428		
11	7.17	2.02	0.535	0.203	0.0990	0.0518	0.0165	
12	8.53	2.40	0.637	0.254	0.118	0.0616	0.0196	
13	10.0	2.82	0.747	0.298	0.138	0.0723	0.0230	
14	11.6	3.76	0.995	0.396	0.184	0.0963	0.0306	

Instruction:

1. The actual pressure drop of section pipeline = list value \times length/ (100 x compression ratio).
(Compression ratio = list pressure + 1)
2. The total pressure drop should add the pressure loss produced in the valve, joint, bend and the changed diameter pipe. These parameters can be found in related brochure.

d. the connection and arrangement of air pipeline

- 1、 Generally should use welding connect the air pipeline, but should use the corresponding flange or screw threaded connection in the joint of equipment and valve. The section which is often removed, should use screw threaded connection when the pipe diameter is less than or equal to DN25, and use flange connection when more than DN25.
- 2、 In order to facilitate discharging oil-water out of the pipe when delivering the undried and unpurified compressed air through the pipeline, there should be more than 2/1000 slope in the pipe line, no draining valve (plug) in the low place, few turning and short straight, few valves as soon as possible.
- 3、 The top of underground pipeline is covered no less than 0.7 m. It is not limited to dried and purified air compressor pipe.
- 4、 The installation position and surface size of the pressure and flow instrument should be seeing the indicated pressure clearly by the operator. The pressure scale range should make working pressure on the 1/2 ~ 2/3 of dial.
- 5、 There should be take pressure strength and tightness test, unfavorable for hydraulic pressure test after installing the system. It is qualified via test with the same air of 1.05 ~ 1.5 times pressure if no leakage,.
There are different choices according to the degree of drying and purifying compressed air which the customer requires. According to the using condition of equipment, choose post-processing devices: storage tank, drying machine, precision filter, and etc. best configuration should be: air-water separator + storage tank+ pre-filter + drying machine + precision filter.
- 6、 Storage tank belongs to pressure vessel. There should be complete safety accessories: the safety valve, pressure instrument, drain valve etc. Should keep record in the local labor department and inspect it routinely every year.

Chapter Six: Operational Guidelines

a check before start for the first time

- 1、 Check the lubricating oil volume in the oil-air separator. Make sure the oil surface is better above the middle of the oil-level table's upper limit and lower limit after normal operation.
- 2、 Electrical wiring and grounding line has been connected, and conform to the safety standard.
- 3、 Make sure supply air pipeline dredges, and all bolts, connectors are tighten.
- 4、 Check whether the motor power, voltage and instrument panel instructions are correct, and ensure the compressor start with no-load.

- 5、 If test the machine after delivery a long time later, should add 0.5 liters of lubricating oil to the inlet and rotate several turns manually or move a few times, in order to prevent the compressor start to burning without oil. Please pay attention not to let other objects fall into the machine body or else will damage to the compressor.
- 6、 Operate the valve according to the requirement of pipeline technology. Compressor exhausting valve is unlocked.
- 7、 Make sure the operators in a safe place when machine start.
- 8、 Close the drain valve by manual.

b start for the first time

- 1、 Switch on the power and observe whether there is correct on the panel show and phase sequence. If there is abnormal display, eliminate abnormal situation and then turn on the power. This machine has inverse phase protection; it could not start if the main motor is inverse turn. Check the rotation direction to be safe, if it is correct, you can obviously feel the suction in the air filter inlet (attention with a finger); otherwise the phase sequence is wrong, cut off power and change any two wires of the three wires. Notice: it is strictly prohibited to reverse run motor.
- 2、 Press the "start" button, the compressor can be work according to the set mode. At this time, observe whether normal of the display panel, pressure temperature, or abnormal sound, oil leakage. If there is abnormal, stop and check immediately.
- 3、 When press the "stop" button, the machine will stop after finishing unloading. It is normal not to stop immediately.



You can press the emergency stop button only in special abnormal situation. If you need re-start, wait for at least two minutes.

c operate normally

- 1、 Preparation work before starting: check the oil surface of oil-air separator, slightly open the oil discharging valve of at the bottom of the separator in order to eliminate the possible existence of condensed water. Tighten the valve after make sure there is no condensed water. And then open the valve of the supply air.
- 2、 Start: switch on the power, and click the "ON (I)" on the panel, then the compressor start working.
- 3、 Stop: click "OFF (O)" on the panel, air compressor will automatically stop after unload for some times. When do not use the machine, cut off the power and close the valve of the supply air.



The compressor will automatically stop when it is in no-load working time longer than the setting time, no inspecting or maintaining at this time because the compressor will resume at any time. Start & stop of the fan is automatic controlled if the machine is with single fan, so doesn't touch the fan avoid cause personal injuries. Cut off the power before checking the machine.

The compressor will suddenly stop if no power. Remember to cut off the power in order to avoid burning electronic parts when there is sudden power supply.

Chapter Seven: Daily Maintenance

Screw air compressor maintenance period and content

maintenance period	(h) working hours	maintenance content
every day	8	Check the oil level before start and during the working, the display situation of panel, the setting pressure. Check the temperature, noise when Oil barrels drainage etc.
every week	80	check the leakage and clean the machine
every three months	500	Check the vacuum index of the air filter and clean it. Replace the oil filter and change the oil if new machine.
every year	1000	Manually check safety valve, thermostat and clean the cooler, electric system remove dust.
	2000	Replace air filter, oil filter, and oil. Check the tightness of the belt and make corresponding adjustment. If beyond the adjustment scope, change it in time. Check the moving parts fastening bolt. Clean the cooler.

	3000	Check whether the thermostatic valve works normally. When the light of the oil-air separator pressure indicator turns on, or oil pressure is higher than the air pressure, check and replace the oil-air separator(in poor environment, its time will be shortened). Clean the cooler. Add grease to motor bearing.
	5000	Replace air filter, oil filter and oil. When the light of the oil-air separator pressure indicator turns on or oil pressure is higher than the air pressure, check and replace the oil-air separator. Clean the cooler.
	10000	Replace Nylon tube, belt, oil meter, solenoid valve, O ring.
	20000	Replace the bearing, the shaft sealing, sound insulation sponge and rubber tubing (Deal with them according to the specific situation).

Attention: The above maintenance is subject to the time coming.

a. Lubricating oil specification and use

Lubricating oil has a decisive influence to oil-injection screw compressor. It will result in serious damage to the compressor if it is used improperly or mistakenly. So please follow the regulations below.

1、 Please use the specific compressor oil.

2、 attention of use lubricating oil

2. 1、 Oil should comply with the requirements. Does not use mix the lubricating oil of different types, false oil and generation oil. The brochure information of the machine has marked the type of the lubricating oil.

2. 2、 Oil performance requirements are as follows: oxidation resistance, resistance to foam, corrosion and abrasion resistance, separating with water strongly, viscosity, high flash point and low pour point.

2. 3、 Don't use the lubricating oil which is beyond its service life, or else lubricating oil quality declines and then the flash point will also decline to burn the machine.

2. 4、 Abide the oil changing period. Oil changing period accords the actual situation. It is suggested that among the first two years, every 3 to 6 months, extracting oil samples to analyze the main indexes of lubricating oil: viscosity, acid value, moisture, ash content, flash point and mechanical impurity, and to determine actual oil changing period, for no waste.

2. 5、 After using the compressor two years later, it would be best to use lubricant oil for a "system cleaning". The way is that continuously changes oil two times, the first work for 6 hours and then the second change.

2. 6、 Oil filter must be changed when changing the lubricating oil.

3、 influencing factors of the time of changing oil

3. 1、 Poor ventilation and too high environment temperature

3. 2、 High humidity environment or the rainy season

3. 3、 Environment of much dust

3. 4、 Mixing different type of lubricating oil for use

4、 oil changing steps

4. 1、 Make the compressor work and then press “stop” button after the temperature going up.

4. 2、 After the exhausting pressure dropping to zero, close the stop valve of compressor air supplying inlet, slowly open the oil discharging valve at the bottom of oil-air separator, discharge its oil, move the air end in clockwise rotation, and add a little new oil to the oil port to thoroughly clean it.

4. 3、 Discharge all the lubricating oil in oil cooler and the oil pipeline system.

4. 4、 Tighten the oil discharging valve at the bottom of the oil-air separator, and add new oil to the oil port. Due to there is no lubricating oil in oil cooler and the oil pipe line system, should add more new oil.

4. 5、 start and check the oil level. If the lever is not enough, stop the machine and add enough lubricating oil.

b、 Control device adjust

Adjustment of safety valve

The discharging pressure of safety valve is generally set to be 1.1 times of the rated discharging pressure. It is set up at the factory, so do not need to adjust it. If must adjust the discharge pressure of the safety valve for other reasons, loosen the lock nut, rotate the screw clockwise, and the discharging pressure will increase. If rotate counterclockwise, the pressure will decrease. Do not forget tighten the lock nut after it.



The discharging pressure of the safety valve is set up at the factory, so do not need to adjust it. If there are special circumstances, should consult relevant professional staff and operate under the guidance, otherwise you undertake all the consequences.

c. The maintenance of machine consumable parts

1 replacement of oil-air separator filter core

When the compressor oil consumption increases greatly, check whether blocking of the oil filter , pipeline, return pipeline and then clean them. Oil-air separator has degraded generally if oil consumption is still big, which should be changed in time. Should replace oil-air separator filter core when it's both ends pressure differential is 0.15M Pa. There is fault with the filter core or air is in short circuit situation when the pressure differential is 0, at this time, should also replace the filter core. Changing steps are as follows:

General replacing time is 3000 to 4000 hours. The time will be shortened if in poor environment. The replacement steps are as follows:

(1) external type machine

- a、 Stop the compressor, close the air exit, open the discharging water valve, and make sure system no pressure.
- b、 Replace new product after removing the oil-air separator.

(2) internal type machine

- a、 Stop the compressor, close the air exit, open the discharging water valve, and make sure system no pressure.
- b、 Disconnect the line above the oil barrel, and disconnect the pipe line from the pressure maintaining valve exit to the post-cooler at the same time.
- c、 Remove the return line.
- d、 Remove the fixed bolts of the oil barrel cover and then remove the oil barrel cover.
- e、 Take off the oil-air separator and change a new one.
- f、 Install it with the reverse order.



Notice the electrostatic releasing when replacing the oil-air separator. Connect the inner metal nets and the oil barrel shell to prevent electrostatic cumulating cause explosion. At the same time, prevent dirty items falling into the oil barrel so as to affect the compressor operating.

2 replace oil filter

Change the oil filter in time when oil filter need maintenance, or the oil filter blocking light turns on, or contrast is more than 1.5 Kg. If does not change in time, it may cause the machine stopping because the temperature is too high. The more important thing is that the main bearing will be seriously wearing and shorten its life. When install the new oil filter, paint some oil on the washer, spin to the right place, and then manually tighten 3/4 ring. After replacement, check whether there's oil leakage.

3 clean air filter

Usually should change the filter core when operate 1500h, at most 2000 hours, or the negative pressure is greater than 0.63 Kg, or air filter is blocked. In the dust place, changing period should be shortening and pay attention to the cleaning maintenance of the filter core at ordinary times. Replace the filter core should stop the machine, so it is suggested to change a new one or an already cleaned spare one to reduce pausing

time.

Tap two ends of the filter core when clean it in order to remove most of the dust, then blow from inside to outside with 0.2 M Pa compressed air. Pay attention to the nozzle which should be about 25 mm from the fold line. It cannot be used again if there is a lot of grease on the filter paper. When the filter is damaged (even a tiny hole), it cannot be used again, replace it immediately.

4 clean the cooler

Use compressed air sweep cooler reversely and should wash it if blocked seriously. Due to poor cooling effect the main engine temperature too high and the machine will stop if no timely cleaning.

5 the adjustment of the belts

- a、 After operation in the first eight hours, check the belt whether in flabby phenomenon, if any, adjust it, and later adjust again per each 1500 hours. If find the belt flabby, adjust it at any time.
- b、 Shut off power supply when adjust. Under spin the lock nut above the motor mounting bracket and tense the belt to a certain position. Positive and negative rotate the belt wheel to adjust and the belt tension should be modest.
- c、 The belt must be replaced group. No oil splashing onto the belt when replacement.
- d、 The belts installing must not be forcibly pried into by hard items. After installation and operate the new belt some time later should adjust it again.

6 the drainage

When you use the air less or in rainy season, the exhaust temperature is lower than the dew point temperature and the compressed air in the separator can produce drainage, so drain off water before start the machine. Open oil drain valve at the bottom of the barrel and discharge the water until oil flows out. There is a drain valve at the bottom of the storage tank and should drain contamination on time.

d、 The maintenance of screw air compressor

- (1) Please implement the following items if do not use the compressor temporarily:
 - a、 Store in dry place, well ventilated and at suitable temperature.
 - b、 Should change the position of the rotor after three months and make the bearing change the contact point. (It will cause bearing rust if grease run off).
- (2) ine is in neat, formal, clean and good insulation condition.
- (3) Safety device (such as safety valve, insurance device, automatic or protective device) is reliable preserved. Explosion-proof, lightning protection and grounding devices should comply with the safety requirements.

Equipment and work area are neat, clean, no oil mark and with complete sign. Pipeline is in reliable circuit connection.

Chapter Eight: Common Faults and Treatment

faults	reasons	treatment
the compressor can not start	The fuse is burned.	check and replace it
	owe phase or “start” button in bad contact	Check and replace it.
	set exhaust pressure wrongly	re-set it
	the motor overload protection trip/ damage	check & maintain the motor/ waiting for the motor cooling
	AC contactor faults	check & handle & replace
	air end faults	Check and moved the air end.
compressor can not set up pressure	minimum pressure valve leak air	check & adjust
	Inlet valve get stuck in the closed position, and the small hole blocked.	check & adjust
	electromagnetic valve does not work	check the electromagnetic valve/circuit
	the air filter core is seriously blocked	clean/replace the filter core

can not no-load or remain pressure when no-load or safety valve fault	inlet valve does not work well	check the inlet control valve
	electromagnetic valve does not work	check or replace
	the oil-air filter core is blocked	replace
	safety valve adjustment value changes or has fault	re-adjust or replace
exhaust capacity and pressure is lower than normal	air filter core is blocked	clean/replace air filter core
	Oil or air leakage in the system.	check & overcome
	use capacity is larger than compressor exhaust capacity	check the connection of the devices
	inlet valve does not work well	check the inlet control valve
	electromagnetic valve does not work or leak	check or replace
exhaust pressure is overpressure to stopped	pressure transmitter fails in working or there is abnormal interference signal	remove or replace
the exhaust temperature is too high or over temperature protection	the oil level is too low	add oil
	environment temperature is too high	improve the environment ventilation and lower the temperature
	the oil cooler surface is too dirty	clean the oil cooler
	something wrong with the fan or fan motor	check and replace the fan
	the oil filter is blocked	replace the oil filter
	temperature control valve fault	check and replace the temperature control valve

	something wrong with the temperature display control	display panel re-set
When pause, the air end inlet emitting oil.	no unloading process for sudden pause	avoid emergent pause
	Air inlet control valve does not work.	check the air inlet control valve
	Electromagnetic valve does not work.	check or replace
	the smallest pressure valve fault, and no back	check or replace
Lots of consumption compressor oil and oil content in air.	The oil level is too high.	Release some oil, lower the oil level.
	The return oil pipeline or the return oil nozzle is blocked.	remove and clean
	The oil-air separator core is damaged.	replace
	The spring of the smallest pressure valve is flabby.	adjust or replace the spring
	Leak oil of oil pipeline/oil seal.	Check and solve the leakage part.
Full load /no-load operation transform frequently.	PLC fault	Check whether the input indicating light is normal (according to the electrical principle diagram).
	air pipeline leakage	check and repair
	operation pressure and unloading pressure	re-adjust the differential pressure
	The smallest pressure valve is not sealed well.	check or re-deal with the seal surface
	Air consumption is unstable.	Increase the volume of the storage tank.

overload protection	low voltage		transform the circuit
	Exhaust pressure is a little high.		re-adjust pressure control
	air end fault		check the air end
	main motor bearing wear		check and replace
	main motor hot-protector fault		check the motor thermistor
The machine has abnormal sound.	main motor bearing wear		check and replace
	fan motor bearing wear		check and replace
	Air end bearing wear		check and replace
	fan collide with the windshield cover		adjust the space
	the belt loose		adjust
oil leakage	the air end parts	mechanical seal ring aging	replace
		the O ring at oil-air place aging	replace
		the O ring of exhaust cover aging	replace
		Fuel injection flange joint of the air end do not seal well.	replace the sealing part
	oil-air pipeline parts	exhaust pipeline and the O ring of the joint aging	replace
		the joint loose	tighten
	oil-air separator parts	Flange cover do not seal well with the barrel plane.	replace the asbestos gaskets
		O ring of the oil level device aging	replace
	other parts	The sealing surface of suction control valve leak oil.	clean, glue and re-install
		The sealing surfaces of the oil filter leak oil.	replace or install after cleaning

Work: continuously work.

Maintenance

Often keep the use environment dry, the motor surface clean. The air inlet shall not be affected by dust, fiber, and other obstacles.

Should check motor whether overload or low setting value of protection device when the motor's heat-protector and short circuit protection always fault. It can be work again only after removing the fault.

Ensure that there is good lubrication in the motor bear work. When running 2000 h, should add grease which is the UNIREXN2 oil that ESSO company produces. The amount is determined as below:

$$G_p=0.005DB$$

G_p= injection volume of fulfill grease, g

D=bearing outside diameter, mm

B= total bearing width, mm

Grease will accelerate aging along with temperature rising, so when the temperature is over 70 °C, each 15 °C rising, time of add must be reduced by half, but the highest temperature should not exceed 120 °C. When temperature is below 70 °C, the interval can be appropriately extended, but even in the lowest temperature operation, the interval also should not be more than 3000 hours.

.Chapter Nine: Maintenance Record
